

NOTE:

- MATERIAL :
HOUSING : THERMOPLASTIC UL94V-2, IVORY COLOR.
CONTACT : COPPER ALLOY.
- FINISH:
CONTACT : TIN PLATED ON CONTACT AREA. NICKEL UNDERPLATED OVER ALL.

38.4	35.00 ±0.20	40.0	15	1-1470225-5
35.9	32.50 ±0.20	37.5	14	1-1470225-4
33.4	30.00 ±0.20	35.0	13	1-1470225-3
30.9	27.50 ±0.20	32.5	12	1-1470225-2
28.4	25.00 ±0.20	30.0	11	1-1470225-1
25.9	22.50 ±0.15	27.5	10	1-1470225-0
23.4	20.00 ±0.15	25.0	9	0-1470225-9
20.9	17.50 ±0.15	22.5	8	0-1470225-8
18.4	15.00 ±0.15	20.0	7	0-1470225-7
15.9	12.50 ±0.10	17.5	6	0-1470225-6
13.4	10.00 ±0.10	15.0	5	0-1470225-5
10.9	7.50 ±0.10	12.5	4	0-1470225-4
8.4	5.00 ±0.10	10.0	3	0-1470225-3
5.9	2.50 ±0.10	7.5	2	0-1470225-2
C	B	A	POS.	PART NUMBER

B	REVISED	FZ00-0167-02	OH/JC	30JUL 2002
A	REVISED	FZ00-0115-02	OH/JC	17MAY 2002
0	FIRST RELEASED	FZ00-0009-02	OH/JC	22JAN 2002
LTR	REVISION RECORD	ECN	DWN/CHK	DATE

DWN	O. HU		TYCO HOLDINGS (BERMUDA) VII LTD. TAIWAN BRANCH		
	30-JUL-2002		CHK	J. CHENG	30-JUL-2002
MATERIAL	SEE NOTE	APVD	J. WU	2.5mm PITCH EMIX, POST HEADER, RIGHT ANGLE.	
FINISH	SEE NOTE	PRODUCT SPEC	30-JUL-2002		108-57175
QUALIFICATION TEST REPORT	501-57195	LOC DW	SIZE A ₃	DRAWING NO C-1470225	REV B
WEIGHT		SCALE	--	SHEET	1 OF 2

POLY BAG

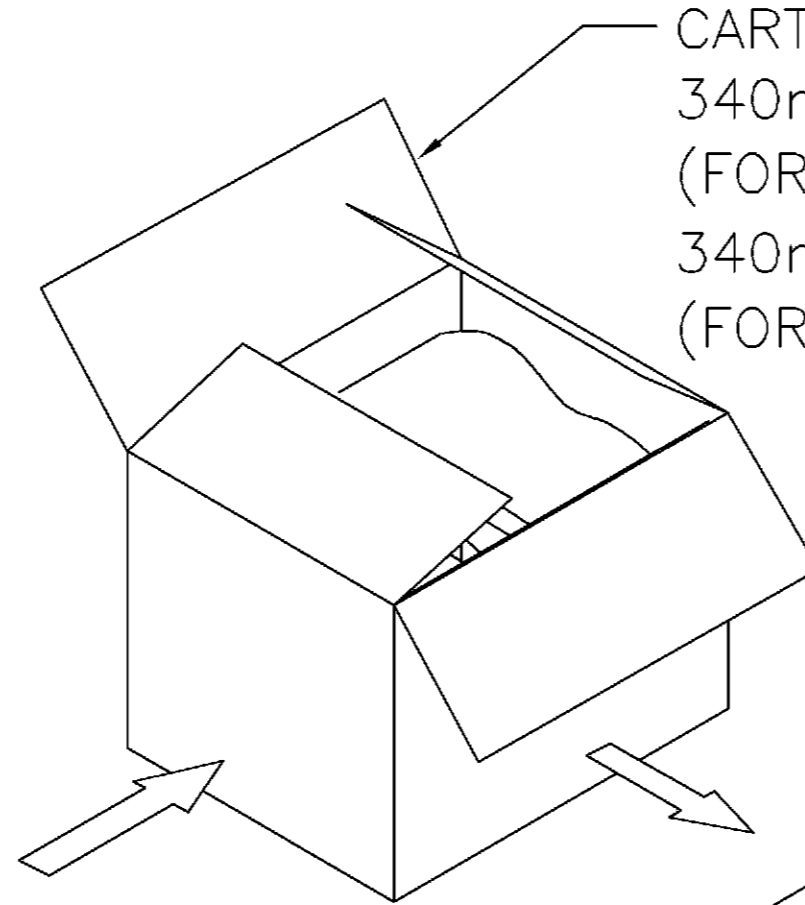
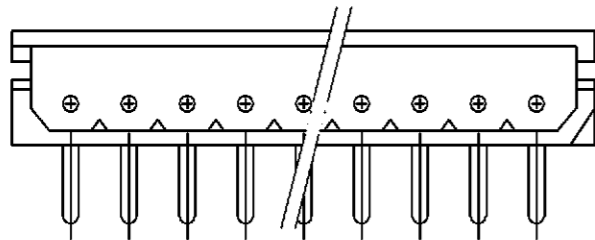

CARTON
 340mm(L)X470mm(W)X158mm(H)
 (FOR P/N 0-1470225-2~0-1470225-5)
 340mm(L)X470mm(W)X316mm(H)
 (FOR P/N 0-1470225-6~1-1470225-5)

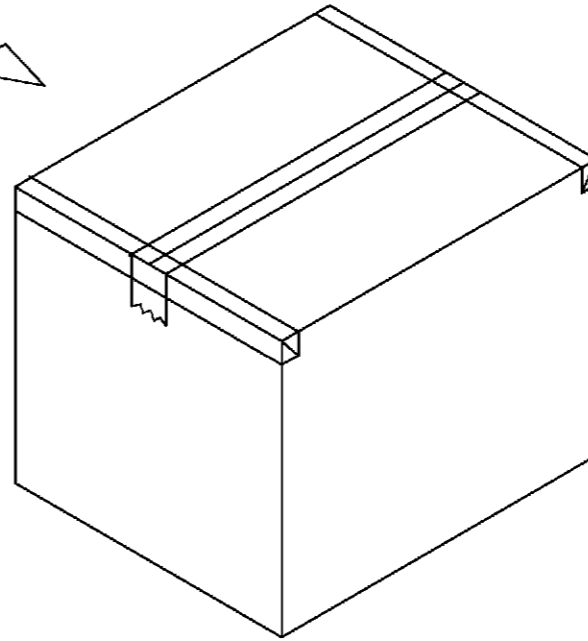

8,320	130	1-1470225-5
9,000	150	1-1470225-4
10,080	180	1-1470225-3
11,520	180	1-1470225-2
12,000	200	1-1470225-1
14,000	250	1-1470225-0
14,000	250	0-1470225-9
16,800	300	0-1470225-8
21,600	300	0-1470225-7
22,400	350	0-1470225-6
14,400	400	0-1470225-5
18,000	450	0-1470225-4
24,000	600	0-1470225-3
32,000	800	0-1470225-2
APQ (PCS/CARTON)	PPQ (PCS/BAG)	PART NUMBER

SEE SHEET 1.	ECN	DWN	CHK	DATE
LTR	REVISION RECORD			

DIMENSION : 0 PLC ±0.5 1 PLC ±0.2 2 PLC ±0.1 3 PLC ±0.05 ANGLES ±3°	DWN	O. HU	TYCO HOLDINGS (BERMUDA) VII LTD. TAIWAN BRANCH			
	CHK	J. CHENG	Electronics NAME			
MATERIAL	APVD	J. WU	2.5mm PITCH EMIX, POST HEADER, RIGHT ANGLE.			
SEE NOTE	PRODUCT SPEC	30-JUL-2002				
FINISH	APPLICATION SPEC		LOC	SIZE	DRAWING NO	REV
SEE NOTE	WEIGHT		DW	A ₃	C-1470225	B
			SCALE	--	SHEET	2 OF 2